

This information provided by:

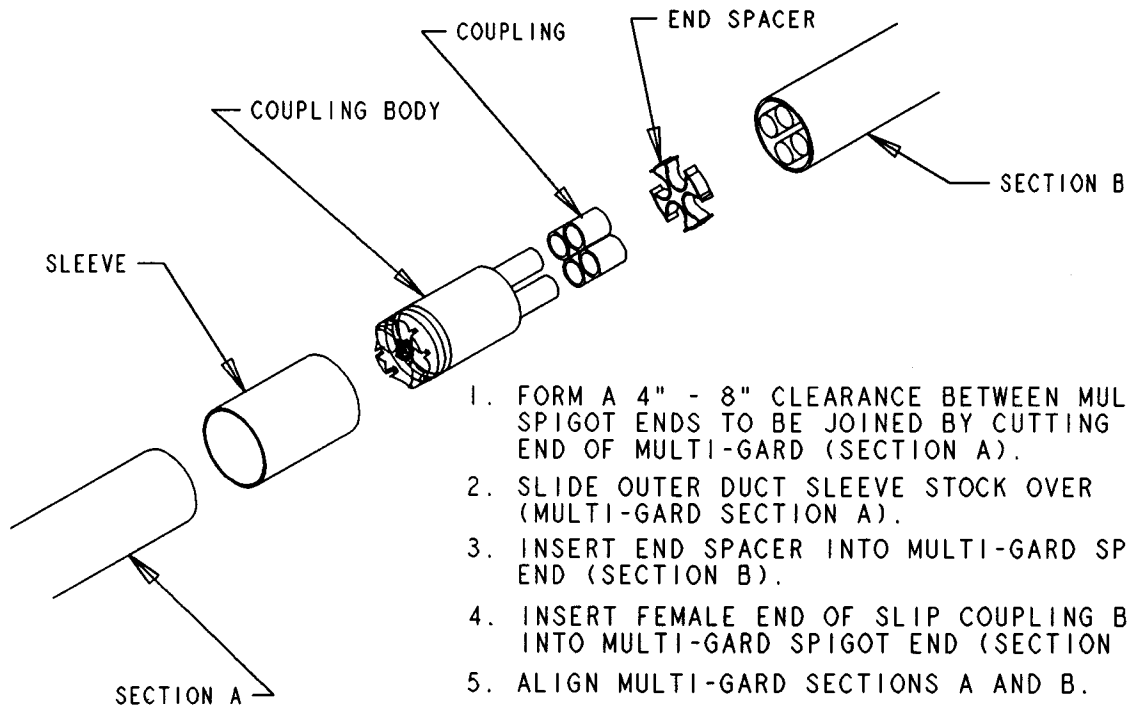

Gross Automation
www.grossautomation.com

Call Toll Free:
800-349-5827



1. FORM A 4" - 8" CLEARANCE BETWEEN MULTI-GARD SPIGOT ENDS TO BE JOINED BY CUTTING ONE END OF MULTI-GARD (SECTION A).
2. SLIDE OUTER DUCT SLEEVE STOCK OVER (MULTI-GARD SECTION A).
3. INSERT END SPACER INTO MULTI-GARD SPIGOT END (SECTION B).
4. INSERT FEMALE END OF SLIP COUPLING BODY INTO MULTI-GARD SPIGOT END (SECTION A).
5. ALIGN MULTI-GARD SECTIONS A AND B.
6. APPLY SOLVENT CEMENT TO INSIDE SURFACE OF COUPLINGS ATTACHED TO THE COUPLING BODY.
7. USING SHOULDER ON SLIP COUPLING BODY SLIDE BODY BACK ONTO INNERDUCT IN MULTI-GARD (SECTION B) UNTIL FIRMLY SEATED.
8. EPOXY 2" OF OUTER DUCT ENDS OF MULTI-GARD (SECTIONS A AND B) AND SLIDE SLEEVE STOCK OVER (SECTION B) UNTIL EPOXY IS COVERED AND CENTERED OVER ASSEMBLY.

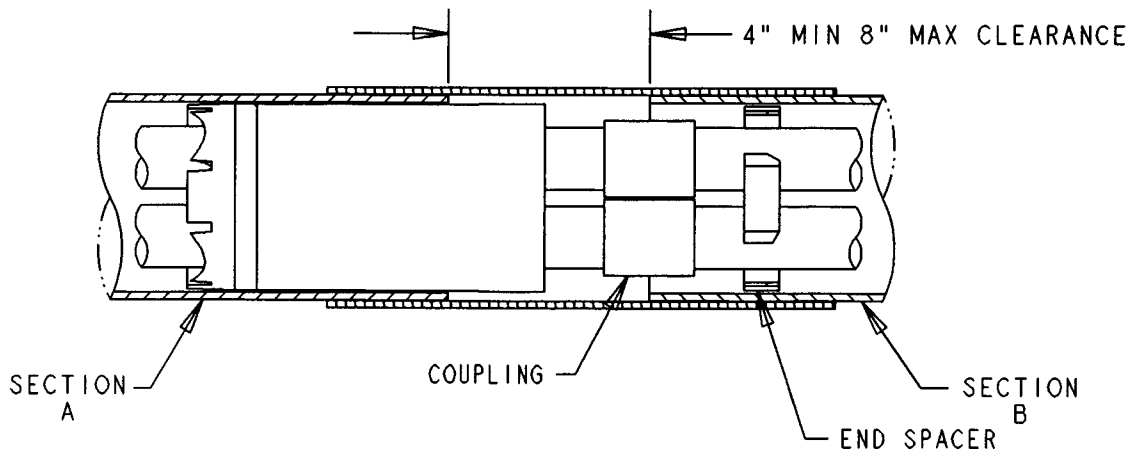

| CATALOG NUMBER | |
|----------------|----------------------|
| M | SC |
| | 3 = 3-WAY INNER DUCT |
| | 4 = 4-WAY INNER DUCT |
| | S = STD. WALL |
| | H = HEAVY WALL |
| | B = BULLET RESISTANT |

| | | | | |
|--|--|--------------------|----------------|-------------------------------|
| TITLE OUTLINE - FIBERGLASS SLIP COUPLING | | DRN DPR | DATE 3-3-03 | PART NO. SEE CHART |
| LAMSON & SESSIONS | ALL DRAWINGS ARE THE PROPERTY OF LAMSON & SESSIONS AND SHALL NOT BE REPRODUCED IN ANY FORM WITHOUT LAMSON & SESSIONS' APPROVAL AND ARE TO BE PROMPTLY RETURNED UPON REQUEST. | APP | DATE | DRAWING NO. AC04345 |
| | | <i>[Signature]</i> | 3/3/03 | REV. A |