

This information provided by:

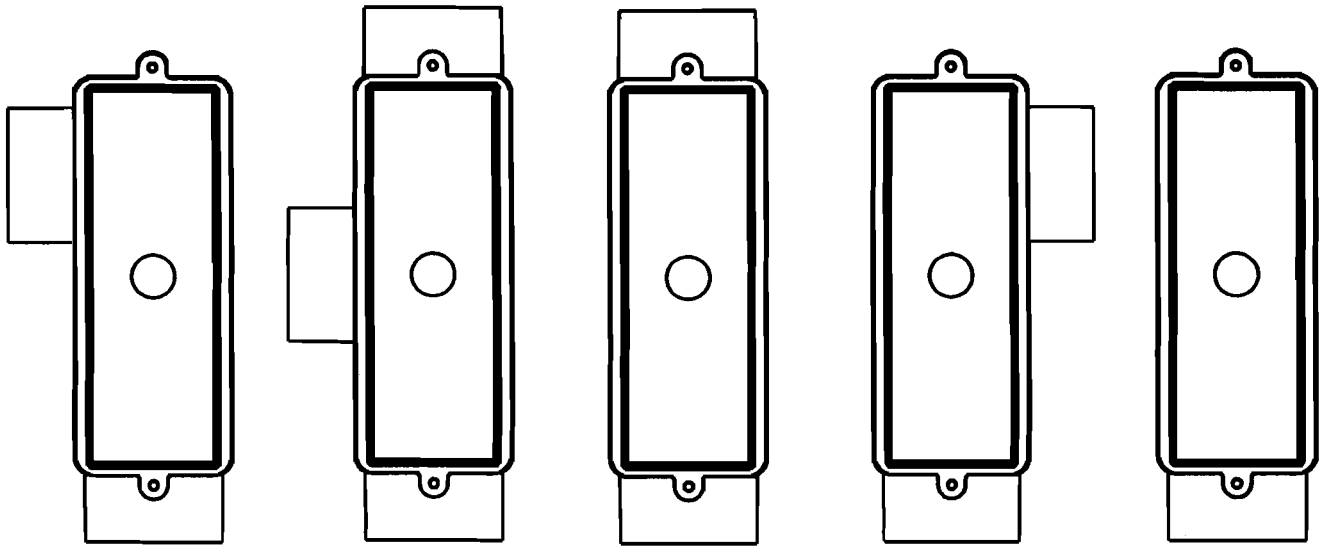

Gross Automation  
[www.grossautomation.com](http://www.grossautomation.com)

Call Toll Free:  
**800-349-5827**



E985H  
TYPE LR

E983H  
TYPE T

E987H  
TYPE C

E984H  
TYPE LL

E988H  
TYPE E

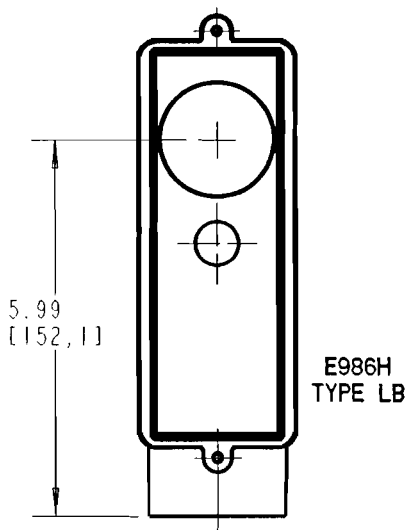

E986H  
TYPE LB

- NOTES:
- FITTING ASSEMBLIES INCLUDE:  
1 - FITTING BODY  
1 - GASKET  
1 - COVER  
2 - SCREWS
  - PORT DIMENSIONS ARE TYPICAL REGARDLESS OF POSITION.
  - DIMENSIONS ARE IN INCH/MILLIMETERS.

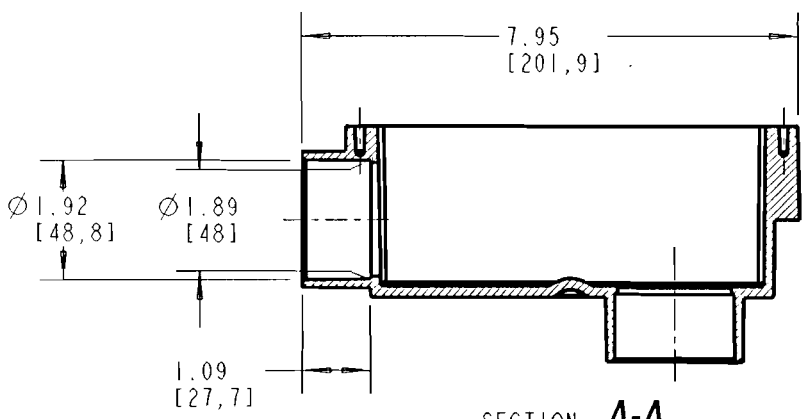
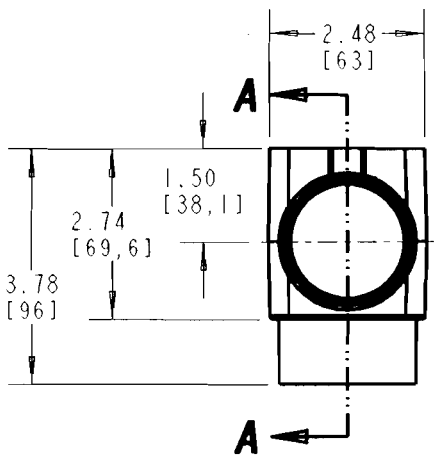

SECTION A-A

TITLE: ACCESS FITTINGS - 1 1/2"		DRN: DPR	DATE: 1-24-06	PART NO: AS NOTED
LAMSON & SESSIONS	ALL DRAWINGS ARE THE PROPERTY OF LAMSON & SESSIONS AND SHALL NOT BE REPRODUCED IN ANY FORM WITHOUT LAMSON & SESSIONS' APPROVAL AND ARE TO BE PROMPTLY RETURNED UPON REQUEST.	APP.	DATE:	DRAWING NO: AC04834
				REV.

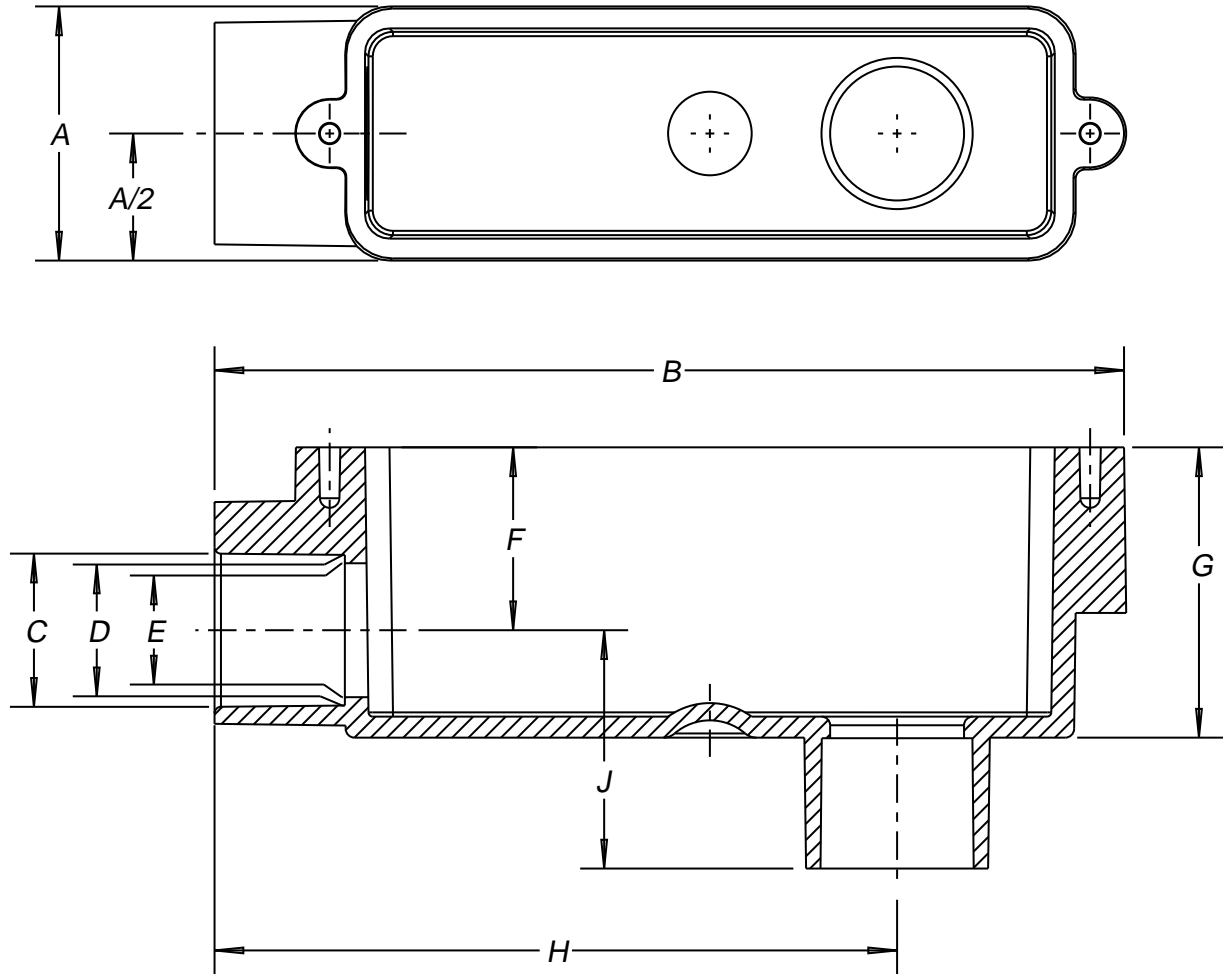

PART NO	SIZE	A	B	C	D	E	F	G	H	J
E986D	1/2"	1.35 [34.3]	4.29 [109.1]	0.85 [21.6]	0.84 [21.3]	0.76 [19.3]	0.82 [21.0]	1.50 [38.1]	3.00 [76.2]	1.31 [33.3]
E986E	3/4"	1.77 [45.5]	6.32 [160.5]	1.06 [26.9]	1.05 [26.7]	0.93 [23.6]	1.27 [32.3]	2.02 [51.3]	4.74 [120.4]	1.76 [44.7]
E986F	1"	1.77 [45.5]	6.32 [160.5]	1.33 [33.8]	1.31 [33.3]	1.25 [31.8]	1.15 [29.2]	2.02 [51.3]	4.74 [120.4]	1.76 [44.7]
E986G	1 1/4"	2.53 [64.3]	7.95 [201.9]	1.68 [42.7]	1.66 [42.2]	1.58 [40.1]	1.64 [41.7]	2.74 [69.6]	6.00 [152.4]	2.28 [57.9]
E986H	1 1/2"	2.53 [64.3]	7.95 [201.9]	1.92 [48.8]	1.89 [48.0]	1.81 [46.0]	1.50 [38.1]	2.74 [69.6]	6.00 [152.4]	2.28 [57.9]
E986J	2"	3.16 [80.3]	9.56 [242.9]	2.39 [60.7]	2.37 [60.2]	2.28 [57.9]	1.92 [48.8]	3.45 [87.6]	7.24 [183.9]	2.57 [65.8]

**NOTES:**

- 1.) PRODUCT, AS SOLD, INCLUDES A GASKET AND COVER.
- 2.) DIMENSIONS ARE: INCH [mm].

TITLE: ACCESS FITTINGS - TYPE "LB"		DRN. DATE DPR 4-13-07	PART NO.: SEE CHART	
LAMSON & SESSIONS	ALL DRAWINGS ARE THE PROPERTY OF LAMSON & SESSIONS AND SHALL NOT BE REPRODUCED IN ANY FORM WITHOUT LAMSON & SESSIONS' APPROVAL AND ARE TO BE PROMPTLY RETURNED UPON REQUEST.	APP. DATE EGH 4-13-07	DRAWING NO.: AC05071	REV.