

This information provided by:



Gross Automation  
[www.grossautomation.com](http://www.grossautomation.com)

Call Toll Free:  
**800-349-5827**

# CARLON

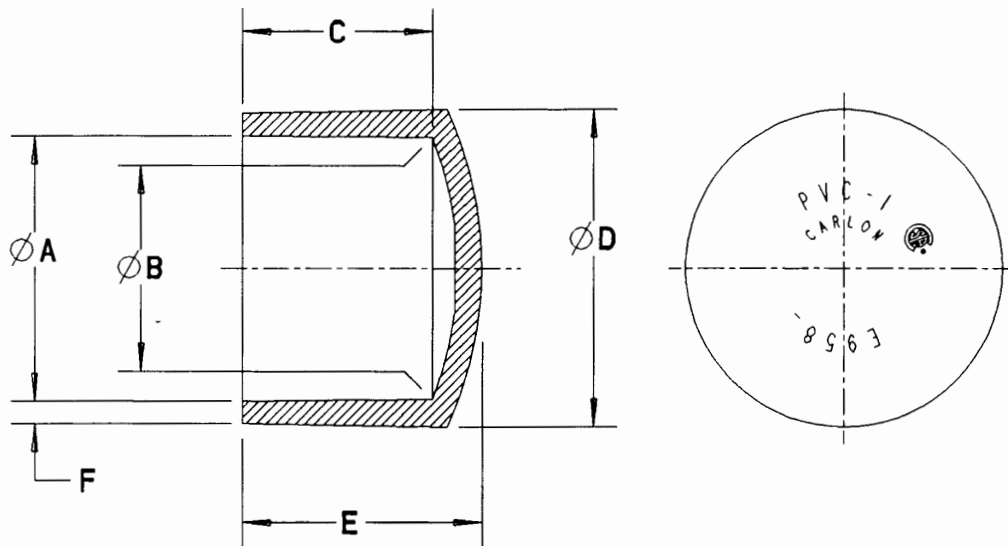

| PART NO. | TRADE SIZE | A               | B               | C<br>MIN. SOCKET DEPTH | D               | E               | F             |
|----------|------------|-----------------|-----------------|------------------------|-----------------|-----------------|---------------|
| E958D    | 1/2"       | .85<br>(21.6)   | .84<br>(21.3)   | .56<br>(14.2)          | 1.18<br>(29.9)  | 1.12<br>(28.4)  | .095<br>(2.4) |
| E958E    | 3/4"       | 1.06<br>(26.9)  | 1.05<br>(26.6)  | .98<br>(24.9)          | 1.37<br>(34.8)  | 1.29<br>(32.8)  | .095<br>(2.4) |
| E958F    | 1"         | 1.33<br>(33.8)  | 1.31<br>(33.3)  | 1.11<br>(28.2)         | 1.67<br>(42.4)  | 1.48<br>(37.6)  | .10<br>(2.5)  |
| E958G    | 1-1/4"     | 1.68<br>(42.7)  | 1.66<br>(42.2)  | 1.25<br>(31.8)         | 2.03<br>(51.6)  | 1.73<br>(43.9)  | .12<br>(3.0)  |
| E958H    | 1-1/2"     | 1.92<br>(48.8)  | 1.89<br>(48.0)  | 1.36<br>(34.5)         | 2.28<br>(57.9)  | 1.7<br>(45.2)   | .12<br>(3.0)  |
| E958J    | 2"         | 2.36<br>(59.9)  | 2.37<br>(60.2)  | 1.44<br>(36.6)         | 2.81<br>(71.4)  | 2.26<br>(57.4)  | .13<br>(3.3)  |
| E958K    | 2-1/2"     | 2.89<br>(73.4)  | 2.87<br>(72.9)  | 2.16<br>(54.9)         | 3.39<br>(86.1)  | 2.95<br>(74.9)  | .165<br>(4.2) |
| E958L    | 3"         | 3.52<br>(89.4)  | 3.49<br>(88.6)  | 2.22<br>(56.5)         | 4.09<br>(103.9) | 3.00<br>(76.2)  | .216<br>(5.5) |
| E958N    | 4"         | 4.52<br>(114.8) | 4.49<br>(114.0) | 2.23<br>(56.6)         | 5.20<br>(132.1) | 3.48<br>(88.4)  | .237<br>(6.0) |
| E958P    | 5"         | 5.59<br>(142.0) | 5.55<br>(141.0) | 3.27<br>(83.1)         | 6.25<br>(158.8) | 4.77<br>(121.2) | .258<br>(6.6) |
| E958R    | 6"         | 6.66<br>(169.2) | 6.61<br>(167.9) | 3.59<br>(91.2)         | 7.39<br>(187.7) | 5.23<br>(132.8) | .28<br>(7.1)  |

NOTE: ALL DIMENSIONS ARE IN INC/MILLIMETERS

|                              |  |             |                |                               |
|------------------------------|--|-------------|----------------|-------------------------------|
| TITLE<br><b>END CAPS</b>     |  | DRN<br>DPR  | DATE<br>2-5-02 | PART NO.<br><b>SEE CHART</b>  |
| <b>LAMSON &amp; SESSIONS</b> | ALL DRAWINGS ARE THE PROPERTY OF LAMSON & SESSIONS AND SHALL NOT BE REPRODUCED IN ANY FORM WITHOUT LAMSON & SESSIONS' APPROVAL AND ARE TO BE PROMPTLY RETURNED UPON REQUEST. | APP.<br>GDT | DATE<br>2-6-02 | DRAWING NO.<br><b>AC04093</b> |
|                              |  |             |                | REV.<br><b>B</b>              |