

This information provided by:

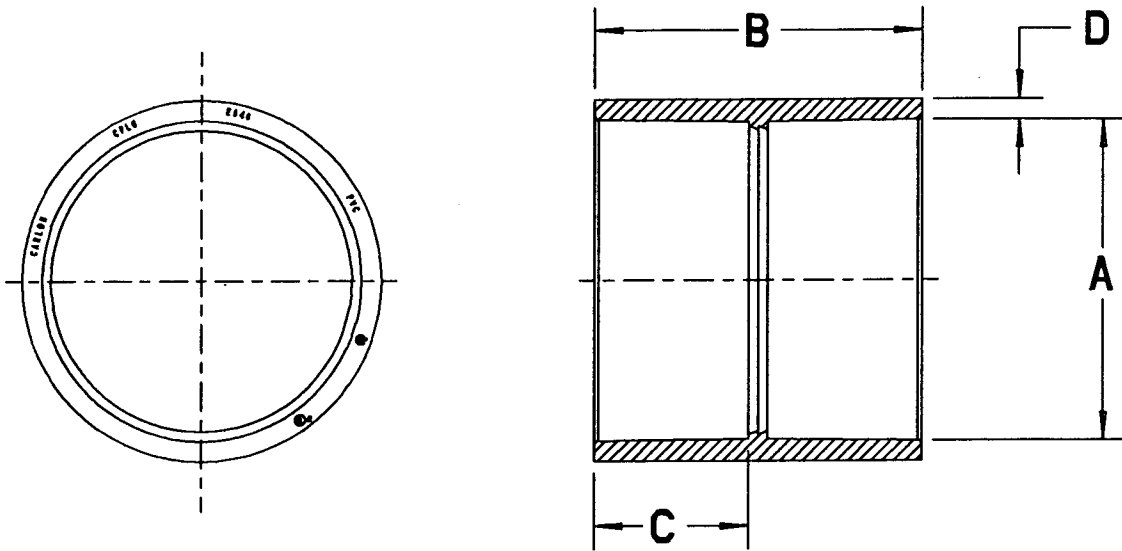

Gross Automation  
[www.grossautomation.com](http://www.grossautomation.com)

Call Toll Free:  
**800-349-5827**



| SIZE   | PART NO.<br>SEE NOTE 1 | PART NO.<br>SEE NOTE 2 | DIM. A          | DIM. B          | DIM. C         | DIM. D       |
|--------|------------------------|------------------------|-----------------|-----------------|----------------|--------------|
| 1/2"   | E940D                  | --                     | .85<br>[21.6]   | 1.42<br>[35.8]  | .68<br>[17.3]  | .11<br>[3.4] |
| 3/4"   | E940E                  | --                     | 1.06<br>[26.9]  | 1.60<br>[40.6]  | .75<br>[19.1]  | .13<br>[3.3] |
| 1"     | E940F                  | --                     | 1.33<br>[33.8]  | 1.91<br>[48.5]  | .90<br>[22.8]  | .13<br>[3.3] |
| 1-1/4" | E940G                  | SCE940G                | 1.67<br>[42.4]  | 2.13<br>[54.1]  | .97<br>[24.6]  | .15<br>[3.8] |
| 1-1/2" | E940H                  | SCE940H                | 1.92<br>[48.8]  | 2.44<br>[61.9]  | 1.13<br>[28.7] | .15<br>[3.8] |
| 2"     | E940J                  | SCE940J                | 2.39<br>[60.7]  | 2.44<br>[61.9]  | 1.15<br>[29.2] | .15<br>[3.8] |
| 2-1/2" | E940K                  | --                     | 2.89<br>[73.4]  | 3.19<br>[81.0]  | 1.50<br>[38.1] | .21<br>[5.3] |
| 3"     | E940L                  | --                     | 3.52<br>[89.4]  | 3.45<br>[87.6]  | 1.63<br>[41.4] | .25<br>[6.4] |
| 3-1/2" | E940M                  | --                     | 4.02<br>[102.1] | 3.67<br>[93.2]  | 1.71<br>[43.4] | .25<br>[6.4] |
| 4"     | E940N                  | --                     | 4.52<br>[114.8] | 3.77<br>[95.6]  | 1.78<br>[45.2] | .27<br>[6.9] |
| 5"     | E940P                  | --                     | 5.59<br>[142.0] | 4.16<br>[105.7] | 1.97<br>[50.0] | .28<br>[7.1] |
| 6"     | E940R                  | --                     | 6.66<br>[169.2] | 4.57<br>[116.1] | 2.15<br>[54.6] | .32<br>[8.1] |

NOTES:

1. MATERIAL: GRAY PVC
2. MATERIAL: ORANGE PVC
3. ALL DIMENSIONS ARE IN INCH/MILLIMETERS.

|   |  |             |                 |                        |           |
|---|--|-------------|-----------------|------------------------|-----------|
| TITLE<br>STANDARD COUPLINGS - SCHEDULE 40 |  | DRN<br>DPR  | DATE<br>3-15-01 | PART NO:<br>SEE CHART  |           |
| LAMSON & SESSIONS                         | ALL DRAWINGS ARE THE PROPERTY OF LAMSON & SESSIONS AND SHALL NOT BE REPRODUCED IN ANY FORM WITHOUT LAMSON & SESSIONS' APPROVAL AND ARE TO BE PROMPTLY RETURNED UPON REQUEST. | APP.<br>WJL | DATE            | DRAWING NO:<br>AC03922 | REV.<br>A |