

This information provided by:

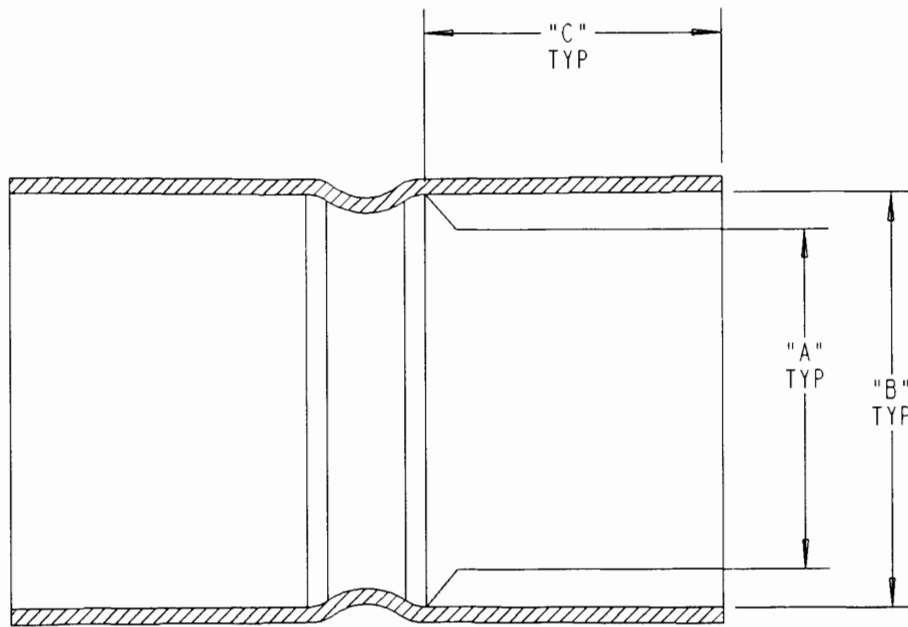

Gross Automation
www.grossautomation.com

Call Toll Free:
800-349-5827



| PART NO. | SIZE | DIM. A | DIM. B | DIM. C | CUT LENGTH (PRIOR TO FORMING) |
|----------|--------|-----------------|-----------------|-----------------|----------------------------------|
| E442J | 2" | 2.38 [60.5] | 2.40 [60.9] | 2.13 [54.1] | 5.0 |
| E442K | 2-1/2" | 2.88 [73.2] | 2.91 [73.9] | 3.00 [76.2] | 6.5 |
| E442L | 3" | 3.52 [89.4] | 3.54 [89.9] | 3.00 [76.2] | 6.5 |
| E442M | 3-1/2" | 3.99 [101.3] | 4.01 [101.6] | 3.61 [91.7] | 7.5 |
| E442N | 4" | 4.51 [114.6] | 4.54 [115.3] | 3.61 [91.7] | 8.0 |
| E442P | 5" | 5.57 [141.5] | 5.61 [142.5] | 4.13 [104.9] | 9.0 |
| E442R | 6" | 6.64 [168.7] | 6.69 [169.9] | 5.13 [130.3] | 10.5 |
| E442T | 8" | 8.64 [219.5] | 8.69 [220.7] | 6.25 [158.8] | 16.0 |

NOTE:

1. ALL DIMENSIONS ARE IN INCH/[MILLIMETERS]
2. "CUT LENGTH" COLUMN IS FOR REFERENCE ONLY, AND REFERS TO THE LENGTH OF THE RAW MATERIAL PRIOR TO THE BELLING OPERATION.

| | | | | | |
|--|--|-------------|------------------|-------------------------------|----------|
| TITLE: COUPLING - SWEDGED - SCH. 40 - 2" THRU 8" | | DRN: RG | DATE: 1/25/02 | PART NO.: SEE CHART | |
| LAMSON & SESSIONS | ALL DRAWINGS ARE THE PROPERTY OF LAMSON & SESSIONS AND SHALL NOT BE REPRODUCED IN ANY FORM WITHOUT LAMSON & SESSIONS' APPROVAL AND ARE TO BE PROMPTLY RETURNED UPON REQUEST. | APP: EGH | DATE: 1/25/02 | DRAWING NO.: | REV.: |
| | | | | AC04091 | B |