

This information provided by:

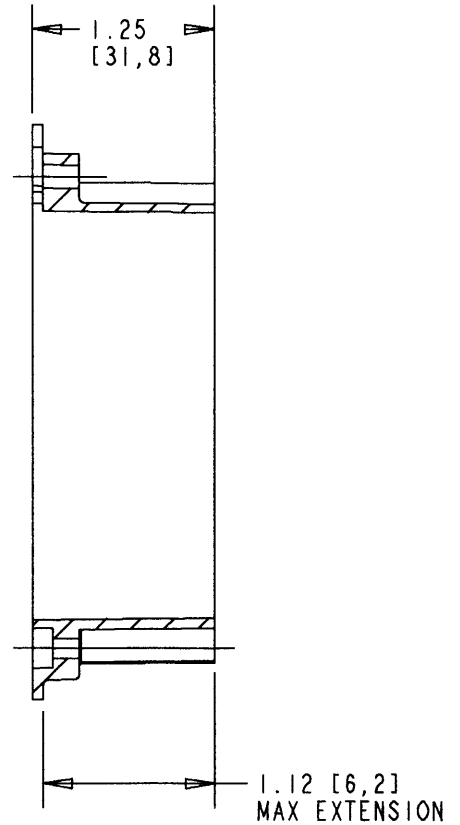

Gross Automation  
[www.grossautomation.com](http://www.grossautomation.com)

Call Toll Free:  
**800-349-5827**

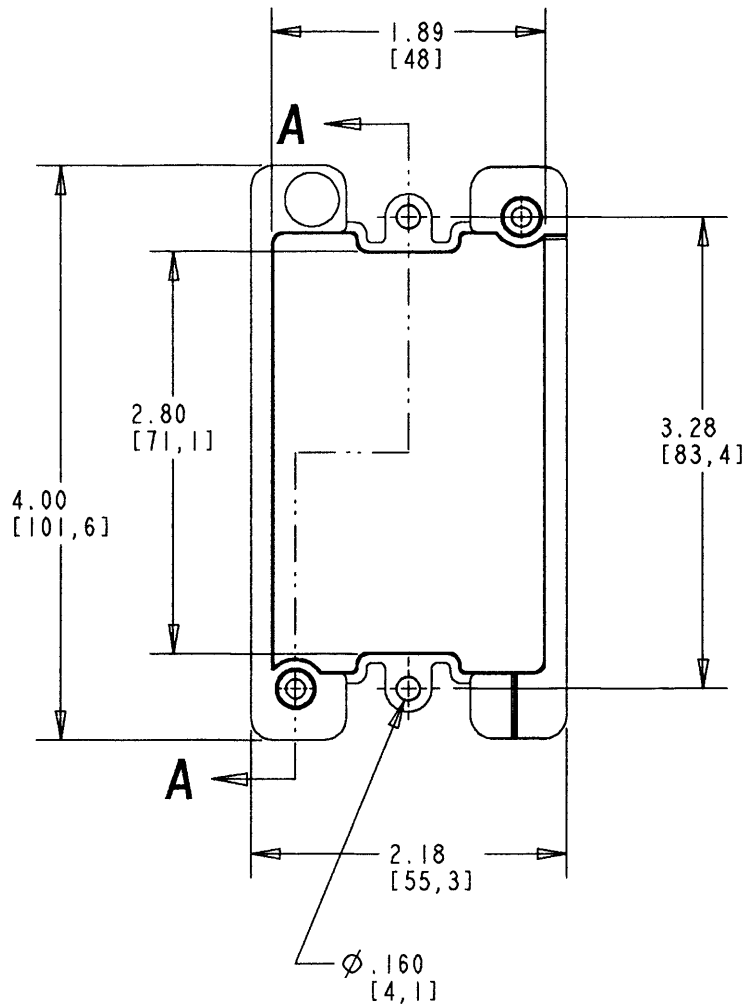

**SECTION A-A**

SCORE MARKS PROVIDE GUIDE FOR CUTTING THRU WALL TO ALLOW GANGABILITY WHEN EXCESS MATERIAL IS DISCARDED

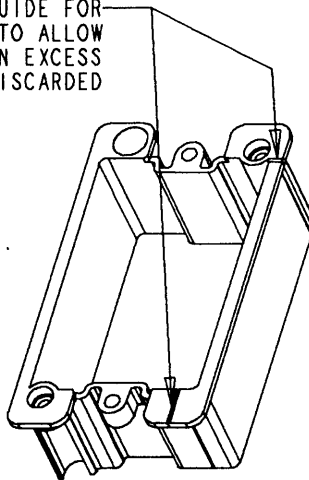

NOTES:  
1. DIMENSIONS ARE SHOWN IN INCHES [MILLIMETERS].

**PRODUCT IS UL LISTED**

BOX EXTENSION	ADDED BOX VOLUME
inches [mm]	in <sup>3</sup> ml <sup>3</sup>
.25 [6,4]	1.36 [22,3]
.38 [9,7]	2.05 [33,6]
.50 [12,7]	2.73 [44,7]
.63 [16]	3.42 [56]
.75 [19,1]	4.10 [67,2]
.87 [22,1]	4.79 [78,5]
1.0 [25,4]	5.47 [89,6]
1.12 [28,5]	6.16 [100]

TITLE: <b>BOX EXTENDER</b>		DRN: <b>PMW</b>	DATE: <b>9-2-97</b>	PART NO: <b>BIEXTB</b>
LAMSON & SESSIONS	ALL DRAWINGS ARE THE PROPERTY OF LAMSON & SESSIONS AND SHALL NOT BE REPRODUCED IN ANY FORM WITHOUT LAMSON & SESSIONS' APPROVAL AND ARE TO BE PROMPTLY RETURNED UPON REQUEST.	APP.	DATE	DRAWING NO: <b>AC03161</b>
				REV. <b>A</b>