

This information provided by:

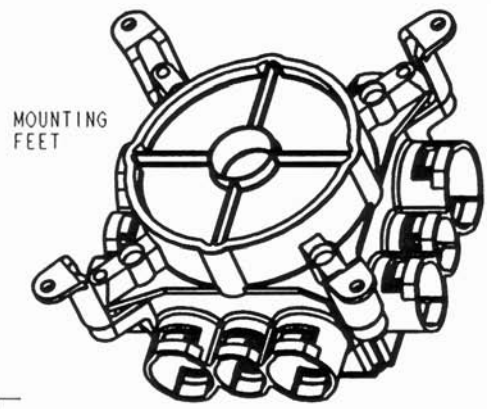

Gross Automation
www.grossautomation.com

Call Toll Free:
800-349-5827

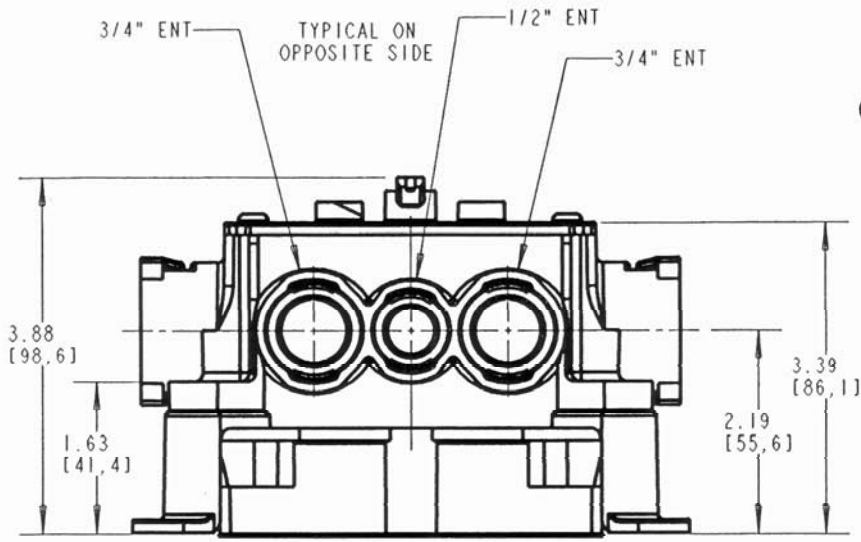

| PART NUMBER | ADDITIONAL (4) MOUNTING FEET |
|-------------|------------------------------|
| A863CF | NO |
| A863CFG | NO |
| A863CFF | YES |
| A863CFGF | YES |

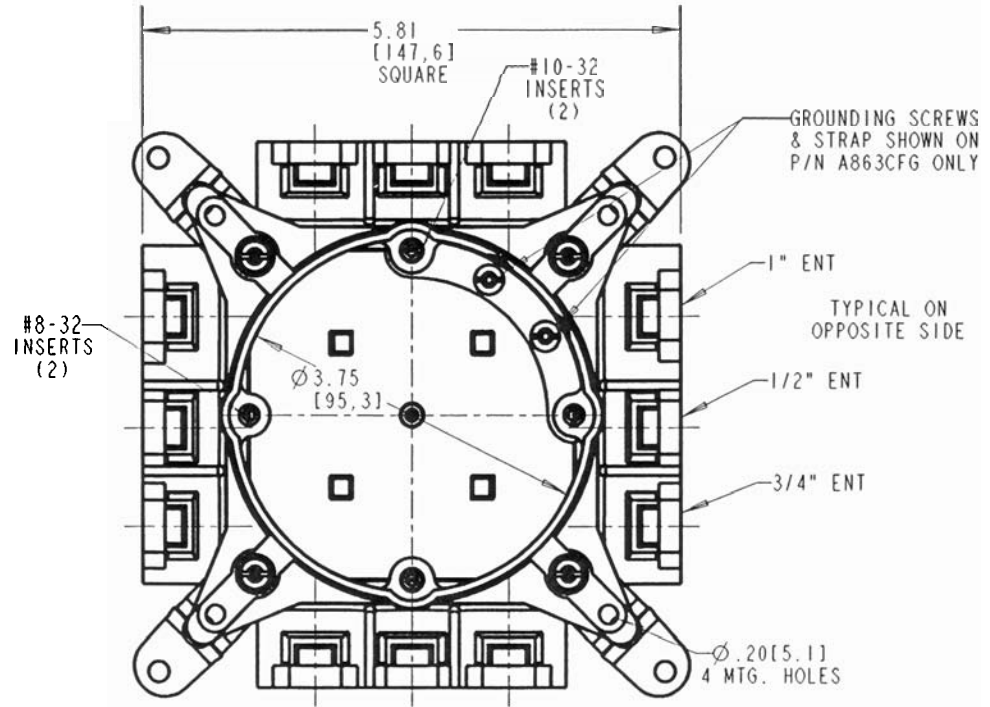

- NOTE:
1. ALL DIMENSIONS ARE IN INCH(MILLIMETERS).
 2. MATERIAL IS BLUE THERMOPLASTIC
 3. P/N A863CF IS WITHOUT GROUND.
 4. BOX IS UL LISTED FOR FIXTURE SUPPORT UP TO 50 LBS.
 5. BOX IS UL LISTED FOR CEILING FAN SUPPORT UP TO 35 LBS.
 6. TWO #8-32 SCREWS SUPPLIED WITH BOX FOR MOUNTING CEILING FAN.

| | | | | |
|---|---|----------|---------------|---------------------|
| TITLE: CEILING FAN & FIXTURE SUPPORT MUDBOX | | DRN: DPR | DATE: 5-1-03 | PART NO: SEE CHART |
| LAMSON & SESSIONS | ALL DRAWINGS ARE THE PROPERTY OF LAMSON & SESSIONS AND SHALL NOT BE REPRODUCED IN ANY FORM WITHOUT LAMSON & SESSIONS' APPROVAL AND ARE TO BE PROMPTLY RETURNED UPON REQUEST | APP: EGH | DATE: 5-14-03 | DRAWING NO: AC04391 |
| | | | | SHEET 1 OF 5 |
| | | | | REV. C |

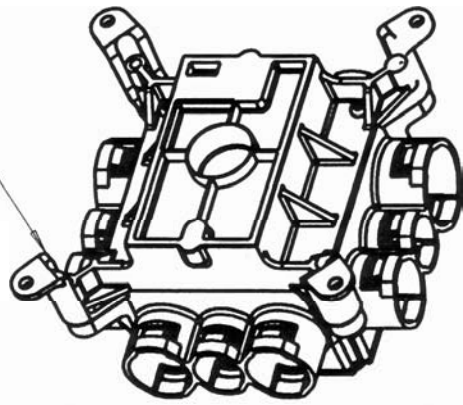

MOUNTING FEET

TYPICAL PATTERN ON OPPOSITE SIDE

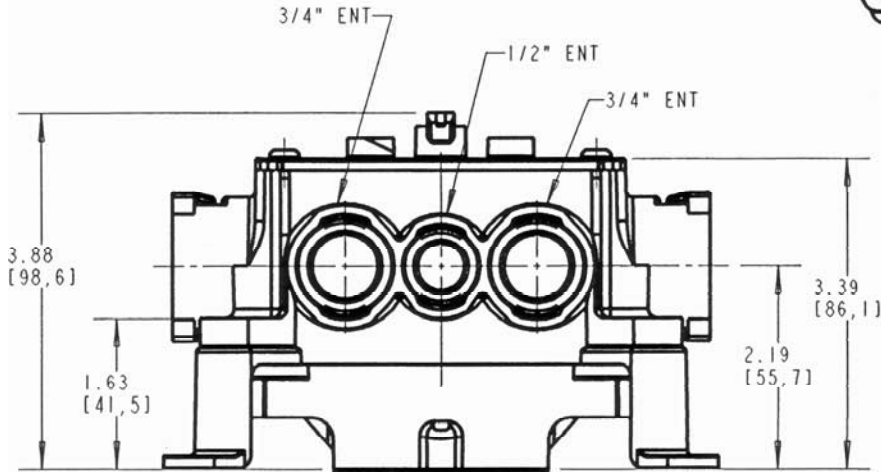

| PART NUMBER | ADDITIONAL (4) MOUNTING FEET |
|-------------|------------------------------|
| A863S | NO |
| A863SG | NO |
| A863SF | YES |
| A863SGF | YES |

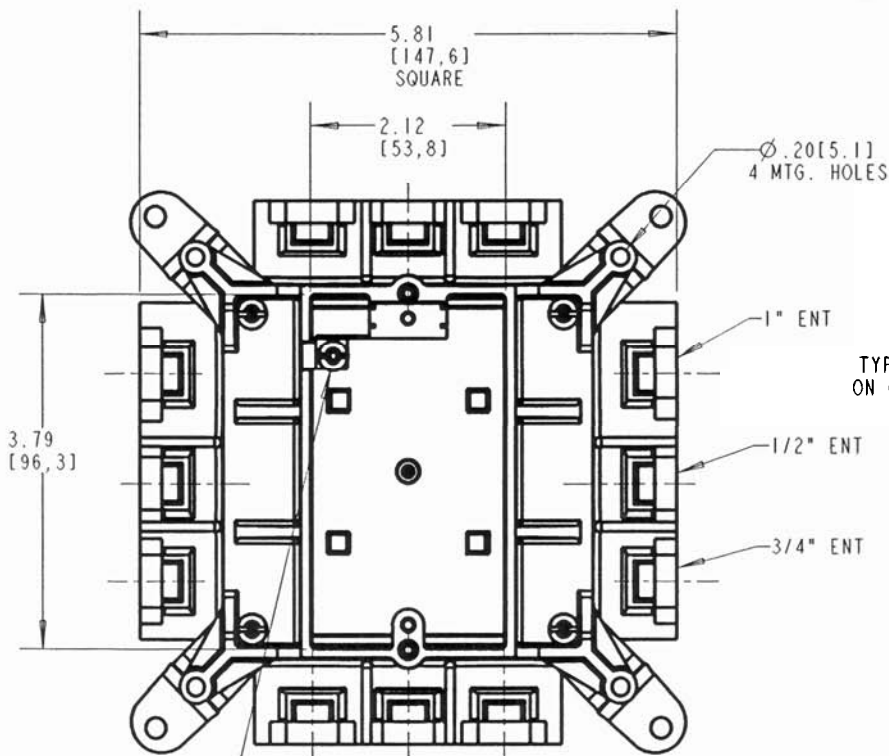

TYPICAL PATTERN ON OPPOSITE SIDE

GROUNDING LUG & SCREW FOR P/N A863SG ONLY

- NOTE:
1. ALL DIMENSIONS ARE IN INCH[MILLIMETERS].
 2. MATERIAL IS BLUE THERMOPLASTIC
 3. P/N A863S IS WITHOUT GROUND.

| | | | | |
|---------------------------|--|----------|---------------|---------------------|
| TITLE: SINGLE GANG MUDBOX | | DRN: DPR | DATE: 5-1-03 | PART NO: SEE CHART |
| LAMSON & SESSIONS | ALL DRAWINGS ARE THE PROPERTY OF LAMSON & SESSIONS AND SHALL NOT BE REPRODUCED IN ANY FORM WITHOUT LAMSON & SESSIONS' APPROVAL AND ARE TO BE PROMPTLY RETURNED UPON REQUEST. | APP: EGH | DATE: 5-13-03 | DRAWING NO: AC04391 |
| | | | | SHEET 2 OF 5 |
| | | | | REV. C |

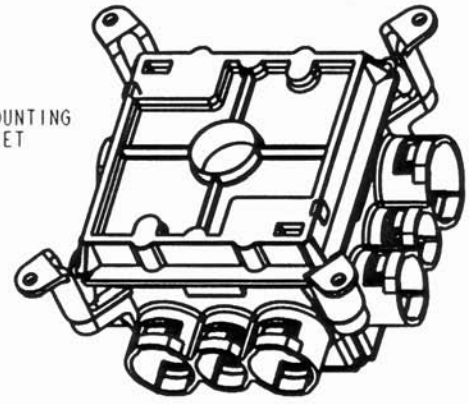

MOUNTING FEET

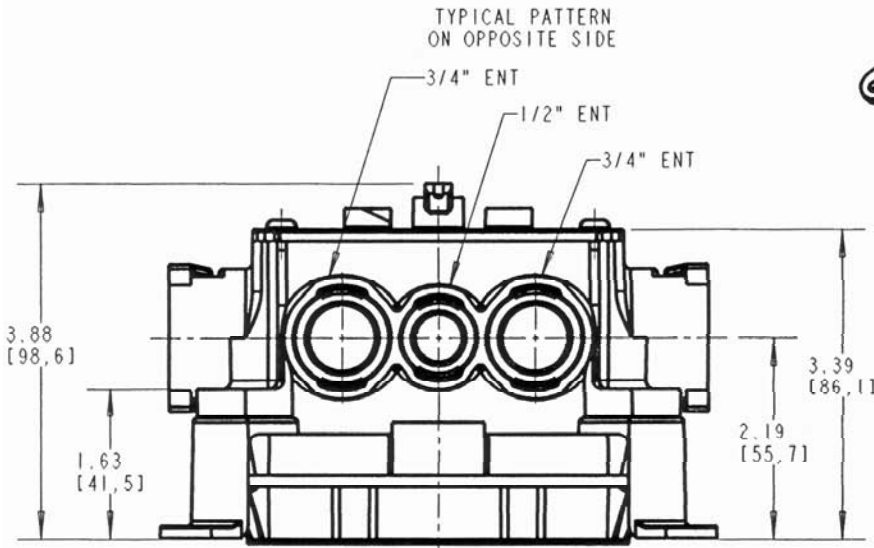

| PART NUMBER | ADDITIONAL (4) MOUNTING FEET |
|-------------|------------------------------|
| A863D | NO |
| A863DG | NO |
| A863DF | YES |
| A863DGF | YES |

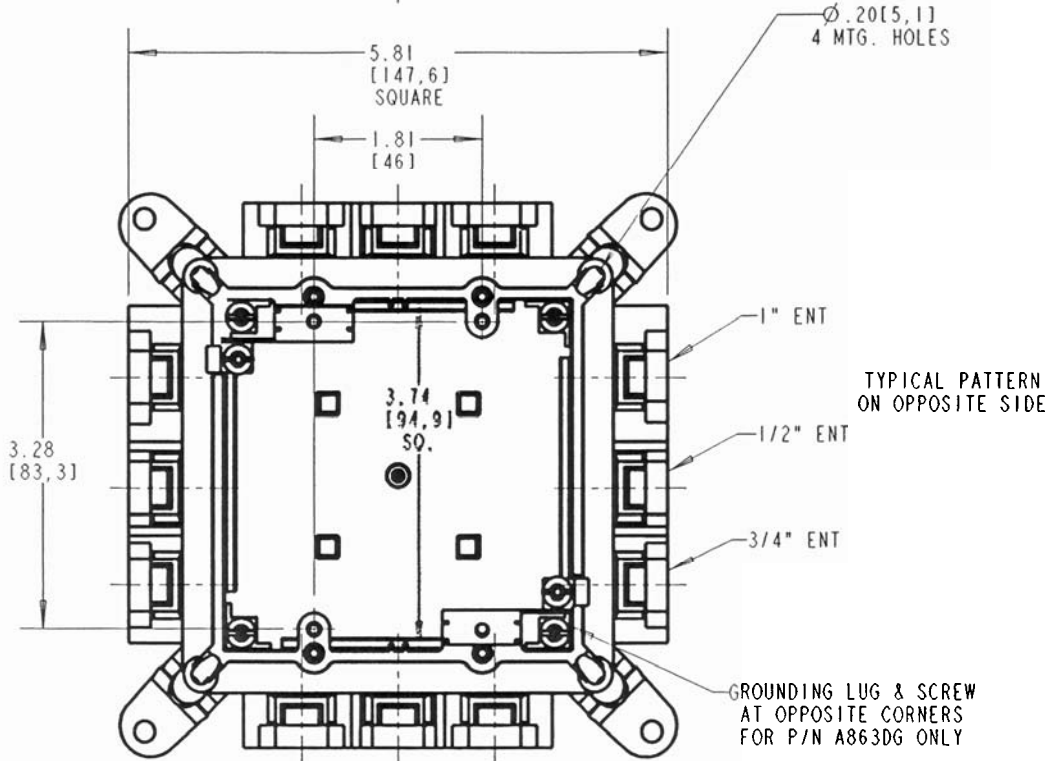

- NOTE:
1. ALL DIMENSIONS ARE IN INCH(MILLIMETERS)
 2. MATERIAL IS BLUE THERMOPLASTIC
 3. P/N A863D IS WITHOUT GROUND.

| | | | | | |
|----------------------|--|----------|---------------|---------------------|--------|
| TITLE: 2-GANG MUDBOX | | DRN: DPR | DATE: 5-1-03 | PART NO: SEE CHART | |
| LAMSON & SESSIONS | ALL DRAWINGS ARE THE PROPERTY OF LAMSON & SESSIONS AND SHALL NOT BE REPRODUCED IN ANY FORM WITHOUT LAMSON & SESSIONS' APPROVAL AND ARE TO BE PROMPTLY RETURNED UPON REQUEST. | APP: EGH | DATE: 5-14-03 | DRAWING NO: AC04391 | REV. C |
| | | | | SHEET 3 OF 5 | |

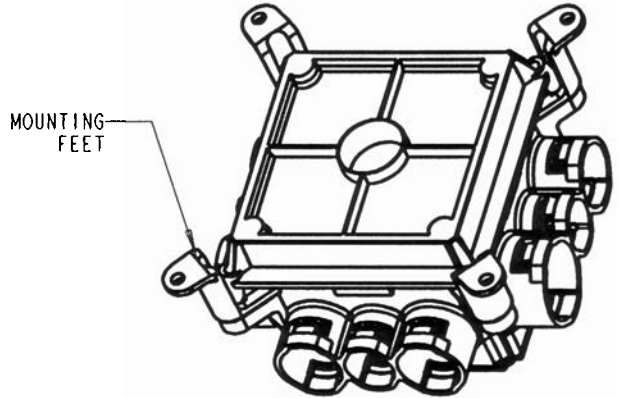

TYPICAL PATTERN
ON OPPOSITE SIDE

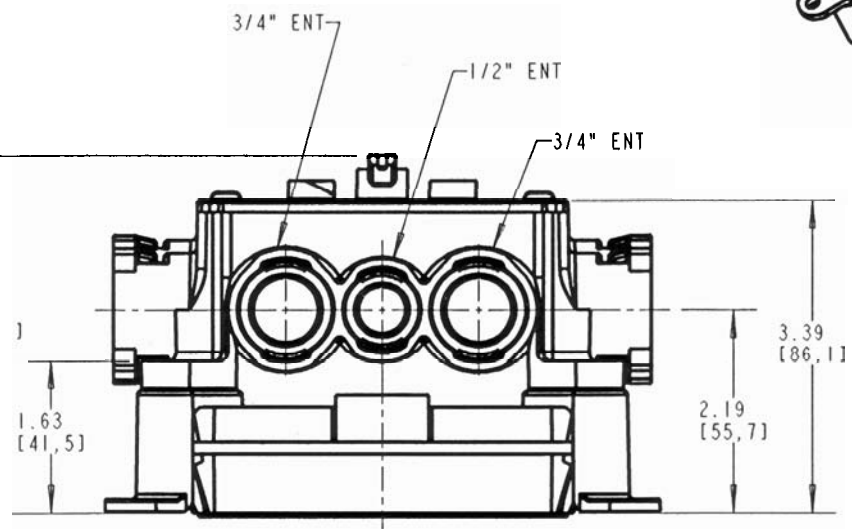

| PART NUMBER | ADDITIONAL (4) MOUNTING FEET |
|-------------|------------------------------|
| A863-4SQ | NO |
| A863-4SQF | YES |

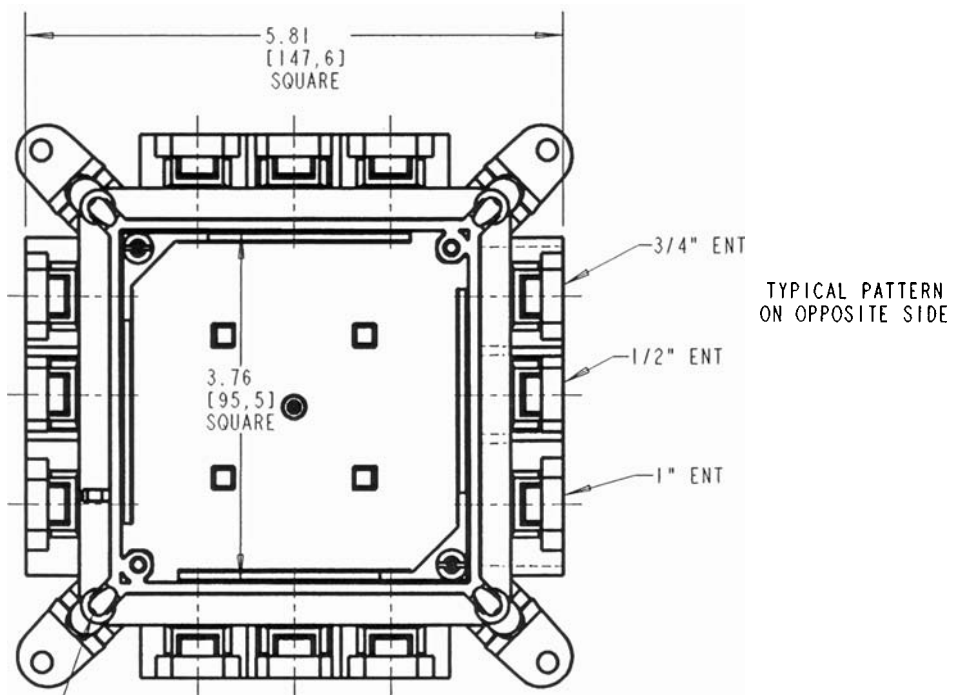

∅ .2015, 11
4 MTG. HOLES

NOTE:
1. ALL DIMENSIONS ARE IN INCH(MILLIMETERS)
2. MATERIAL IS BLUE THERMOPLASTIC

| | | | | |
|----------------------|--|--------------|--------------|---------------------|
| TITLE: 4" SQ. MUDBOX | | DRN. DPR | DATE 5-1-03 | PART NO. SEE CHART |
| LAMSON & SESSIONS | ALL DRAWINGS ARE THE PROPERTY OF LAMSON & SESSIONS AND SHALL NOT BE REPRODUCED IN ANY FORM WITHOUT LAMSON & SESSIONS' APPROVAL AND ARE TO BE PROMPTLY RETURNED UPON REQUEST. | APP. EGH | DATE 5-13-03 | DRAWING NO. AC04391 |
| | | SHEET 4 OF 5 | | |

TYPICAL PATTERN
ON OPPOSITE SIDE

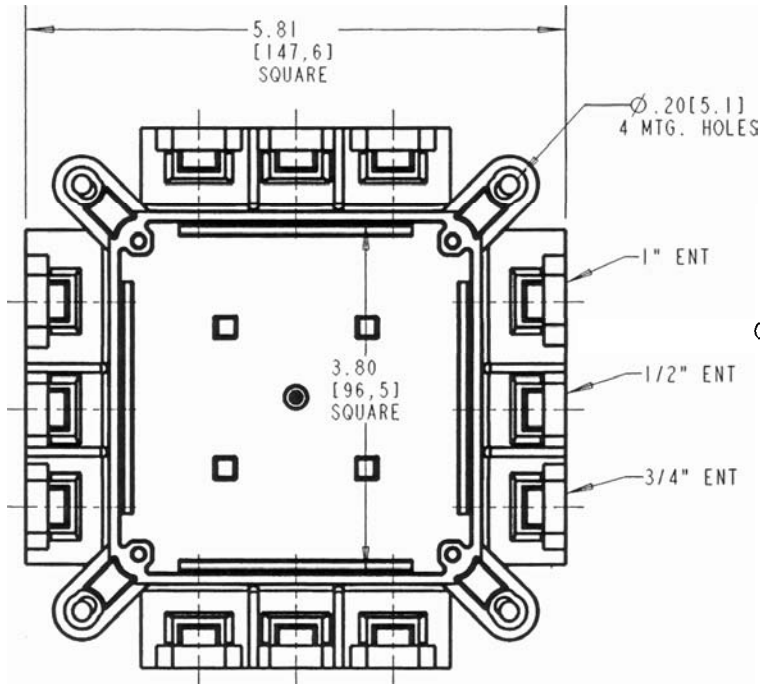
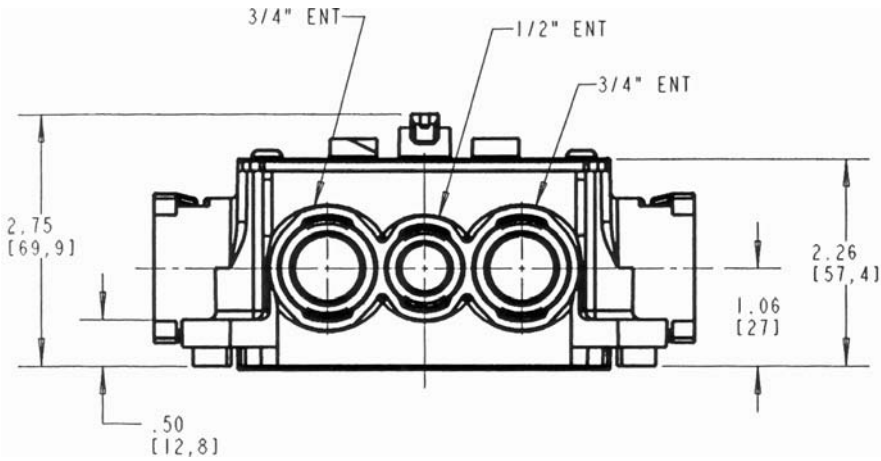
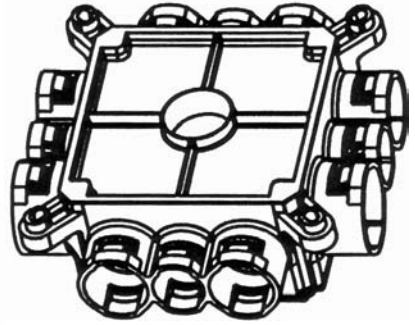

TYPICAL PATTERN
ON OPPOSITE SIDE

NOTE:

1. ALL DIMENSIONS ARE IN INCH(MILLIMETERS)
2. MATERIAL IS BLUE THERMOPLASTIC

| | | | | |
|------------------------------|--|----------|---------------|---------------------|
| TITLE: SHALLOW 4" SQ. MUDBOX | | DRN: DPR | DATE: 5-1-03 | PART NO: A863BC |
| LAMSON & SESSIONS | ALL DRAWINGS ARE THE PROPERTY OF LAMSON & SESSIONS AND SHALL NOT BE REPRODUCED IN ANY FORM WITHOUT LAMSON & SESSIONS' APPROVAL AND ARE TO BE PROMPTLY RETURNED UPON REQUEST. | APP: EGH | DATE: 5-14-03 | DRAWING NO: AC04391 |
| | | | | SHEET 5 OF 5 |
| | | | | REV. C |